



M3-320

MANUAL

Version 1.2

Revision History

Amendment Date	Version
March 2009	V1.0
September, 2010	V1.1
November, 2011	V1.2

Table of Contents

1	Introduction.....	3
2	System Design	4
3	Quick Start.....	6
	3.1 Prepare for connection.....	6
	3.2 Basic connection for M3-320	7
4	General Notes	8
5	Connectors, pinouts & jumpers	11
6	System Setup	17
	6.1 Select switches	17
	6.2 OSD Configuration	17
	6.3 Start up.....	18
	6.3.1 Start track mode	18
	6.3.2 Sleep mode	18
	6.4 Loop Playback	18
7	Operating Instructions	20
	7.1 Operating modes	20
	7.1.1 Playlist mode	20
	7.1.2 Simple play mode.....	20
	7.2 Operating functions.....	21
	7.3 USB Update	22
	7.4 Formatting SD card	23
	7.5 Exporting Project and Playlist	24
	7.6 Network setup	25
8	Dimension.....	27
9	Specification	28

1 Introduction

This brief guide explains how to use and set up your M3-320 decoder board. It is intended for system integrator who assemble ViewStream product for customers, and for resellers.

The M3-320 is an MPEG decoder board designed to use with Video Monitors for playing MPEG-2 video and audio files.

- MPEG-2 video
- JPEG picture
- Video signals of PAL & NTSC standard
- Composite signal output
- DVI output
- Audio output
- RS-232 port
- USB Update
- LAN (RJ-45) port

IMPORTANT USAGE NOTE

- All media filenames must be in 16.3 format (e.g. xxxxxxxx.xxx) though combinations with 7.3, 10.3 etc are fine.

Where: "16" is the maximum of alpha-numeric character to be used.
"3" is the file extension like .mpg / .jpg / .avi etc.

- Do not use any "Non alpha-numeric" characters like '~', '_', '-', '&', '^', etc.

NOTE: If 'Non alpha-numeric character' are used or the '16.3' format are not followed, the player will not recognize the playlist.

This equipment is for use by developers and integrators; the manufacturer accepts no liability for damage or injury caused by the use of this product. It is the responsibility of the developer, integrators or other users of this product to:

- Ensure that all necessary and appropriate safety measures are taken.
- Obtain suitable regulatory approvals as may be required.
- Check power settings to all component parts before connection.

DISCLAIMER

There is no implied or expressed warranty regarding this material.

2 System Design

M3-320 Connector Summary:

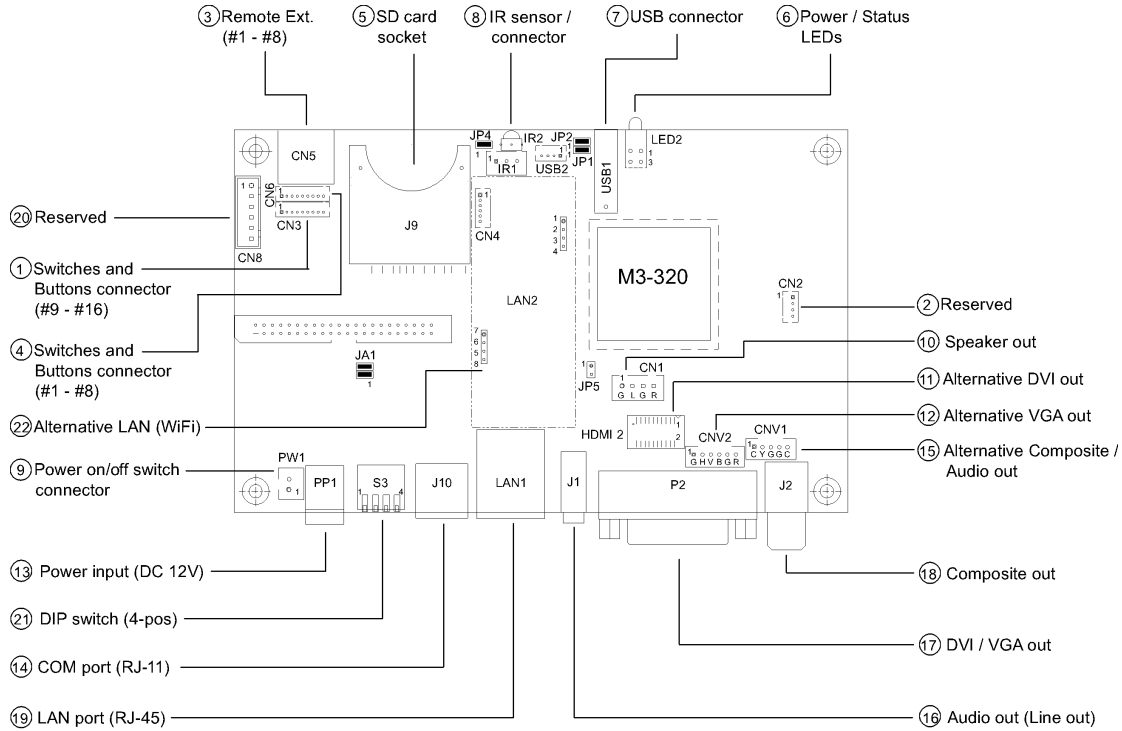

Summary:

1. Switches and buttons connector (1 – 8 button)	13. Power input (DC 12V)
2. Reserved	14. COM port
3. Remote Ext. (1-8 button)	15. Alternative Composite out and audio out
4. Switches and button connector (9 – 16 button)	16. Audio out (Line out)
5. SD card slot	17. DVI / VGA out
6. Power / Status LEDs	18. Composite out
7. USB connector	19. LAN port (RJ-45)
8. IR connector	20. Reserved
9. Power on/off switch connector	21. DIP switch (4-pos)
10. Speaker out connector	22. Alternative LAN (WiFi)
11. Alternative DVI out	
12. Alternative VGA out	

A) Mechanical buttons

- Standard MV-switchmount (P/N:416101300-3) for 1-8 buttons when connected to the button connector CN6 via the standard switchmount cable (P/N:426451100-3) or connected to the Remote Ext. socket (CN5) via the standard cable (P/N:426631800-3).
- Custom made switchmount for 1-16 buttons when connected to the buttons connector CN6 and CN3 via the standard switchmount cable (P/N:426451100-3)
- Custom made switchmount for 1-8 buttons when connected to the Remote Ext. socket (CN5) for alternative remote control buttons via the standard cable (P/N:426631800-3).

B) Touch screen segments

- The M3-320 when connected with a LCD interface controller can output videos on to LCD screen. Button control can be performed via touch screen for panel sizes of 7", 8", 10", 15" and 21.5"
- There is one type of button pattern layouts on the touch screen available: 8 buttons
(For any special button layout, please contact local sales office.)

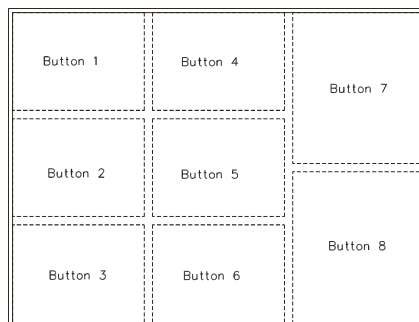

Fig. 1 8-buttons for LCD touch screen

C) Button function settings

- Whether the buttons are of the mechanical type (on the standard switchmount or custom made) or the touch screen segment type, each button function can be programmed with **the DV Studio Software program** to perform a VCD player mode function or specific track select function. (See **DV Studio Software user manual**).
- The DV Studio Software program is separately provided

3.2 Basic connection for M3-320

- Connect the keys pad to CN5 (if required)
- Set the DIP switch#1 (S3) to the chosen output connector.
- If Composite video output is selected, set the DIP switch#2 (S3) for “PAL” or “NTSC” selection.
- Connect the video and audio ext. cables from the M3-320 to the monitor.
- Connect the power supply (DC 12V @ 1.2A minimum. - ensure correct + & - orientation) to the controller power input (PP1).
- Connect the on/off switch cable (p/n:426680401-3) or short Pin1-2 at PW1 for “Auto power on”

For a detailed system setup, go to section 6

4 General Notes

The M3-320 is designed for use with Video Monitors and other analogue signal input displays. Here are some notes for correct use:

- **Preparation** - Before you proceed, please familiarize yourself with the various connectors, jacks, switches and function buttons of the M3-320 unit (see the 'System Design' diagram).
- **The unit** - Handle the unit with care; any knocking may cause components to come loose and disconnect. Operate in a cool and dry place.
- **Power Input:** 12V DC, 1.2A (minimum) is required; this should be a regulated supply. Power connector is using DC jack, 2.5mm diameter (Center +)
- **Video output** – Video - displays PAL & NTSC signals with composite out. The PAL/NTSC switch should be set correctly.
- **Audio output** – Audio - Stereo output. Master volume is controlled through OSD with switch mount buttons.
- **DIP Switch settings (S3)** – To define and select the source of output and USB/LAN.
 - SW1-1 (Output selection):
 - DVI/VGA: If it is selected, the output resolution is set to 1280x720p60Hz*
 - Composite: If it is selected, the video format (PAL/NTSC) is determined by SW1-2.
 - SW1-2 (PAL/NTSC selection): When using Composite output connectors this should be set according to the input requirements of the video display being used.
 - SW1-4 (Content update selection): You may only choose either one way (LAN or USB) to update content without removing SD card.

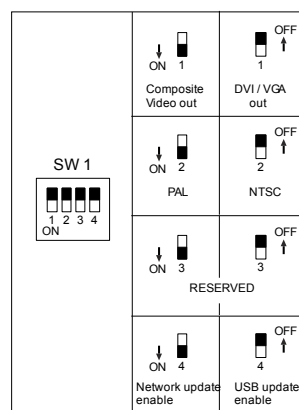

*An optional DVI to VGA adapter is required

- **Remote Ext.** - Using the standard switch mount (p/n: 416101300-3) - 8 momentary buttons for OSD config and video playback control (standard functions (in simple play mode) being: Play, Stop, Pause, Next Track, Volume decrease, Volume increase, Mute). An optional function control device is a custom-made switch mount connected to the switches and buttons connectors (CN6 and CN3) with a maximum of 16 momentary buttons
 - **Remote Ext. cable** - The cables (p/n: 426631800-3) to the switches and buttons connector should be of suitable quality and length so that impedance does not affect performance. Generally lengths up to 1 meter (3 feet) should be acceptable.
 - **LED (LED2)** - The power LED indicator shows power is being supplied to the M3-320. The Status LED indicates the status of SD card.
 - **RS-232 port** – Requires RJ-11 to DB-9 extend cable (p/n:426894301-3) for RS-232 connection. This serial port supports barcode scanner and RS-232 command control. The baud rate must be set to (57600, n,8,1) and record suffix is set to CR (0DH).
 - **USB** – USB Host. Use USB memory stick for content update without removing the SD card. The M3-320 will reset power when the USB stick is detected inserting into the USB connector or removing from the USB connector. (For the details of USB content update, please refer to the Application note.)
 - **DVI out** – Supports DVI or VGA. Both DVI and VGA signal are sharing the same connector. A DVI to VGA adapter is required if connect to VGA.
- Note:** This DVI/VGA out is currently set to 1280x720 resolution which may not be supported by all monitors. If the display looks reasonable but not perfect please use the OSD settings of the monitor to adjust image position and tuning. (sometimes called *Phase*, *H. size*, *H. Freq*, etc) It may also be necessary to adjust image size.
- **Infra-red (IR)** - Supports IR control with DV remote control handset (P/N:559000104-3). The IR sensor and cable kit (P/N:446010401-3) are required. The IR control functions are shown as below.

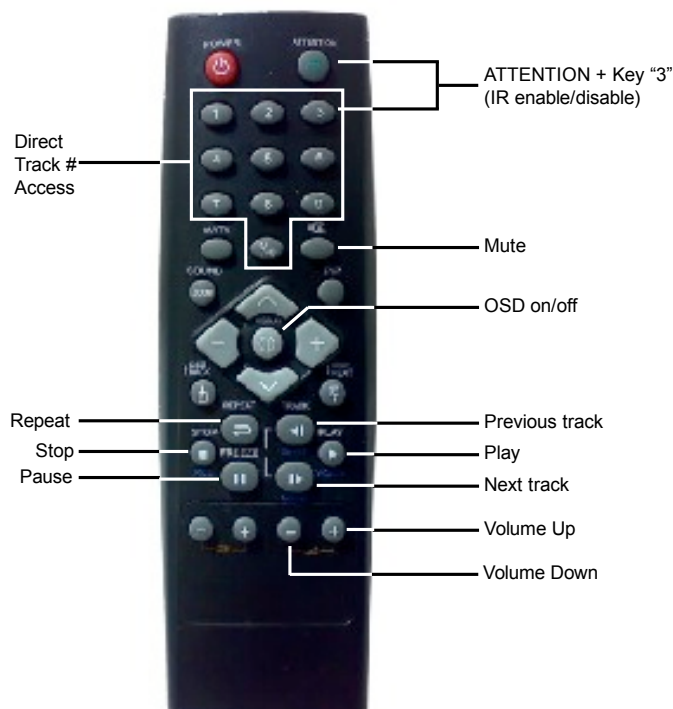

- **Service & Warranty:** Warranty is invalidated if the unit is dismantled in any way. The unit is not user serviceable or repairable.

CAUTION: Do not attempt to remove any part of the casing or internal parts.

Details:

CN1 – Speaker out (Left / Right)

PIN	SYMBOL	DESCRIPTION
1	L+	Left positive
2	L-	Left negative
3	R+	Right positive
4	R-	Right negative

CN3 – Switches and buttons (#9 - #16)

PIN	SYMBOL	DESCRIPTION
1	SW9	Button 9
2	SW10	Button 10
3	SW11	Button 11
4	SW12	Button 12
5	SW13	Button 13
6	SW14	Button 14
7	SW15	Button 15
8	SW16	Button 16
9	GND	Ground

CN5 – Remote Ext.

PIN	SYMBOL	DESCRIPTION
1	SW1	Button 1
2	SW2	Button 2
3	SW3	Button 3
4	SW4	Button 4
5	SW5	Button 5
6	SW6	Button 6
7	SW7	Button 7
8	SW8	Button 8

The shielding of connector is grounded.

CN6 – Switches and buttons (#1 - #8)

PIN	SYMBOL	DESCRIPTION
1	SW1	Button 1
2	SW2	Button 2
3	SW3	Button 3
4	SW4	Button 4
5	SW5	Button 5
6	SW6	Button 6
7	SW7	Button 7
8	SW8	Button 8
9	GND	Ground

CNV1 - Alternative Composite and Audio output

PIN	SYMBOL	DESCRIPTION
1	AUDIO_RIGHT	Audio right output
2	AUDIO_LEFT	Audio left output
3	GND	Ground
4	GND	Ground
5	CVBS	Composite video out

CNV2 - Alternative VGA output

PIN	SYMBOL	DESCRIPTION
1	GND	Ground
2	H_SYNC	Horizontal Sync Output
3	V_SYNC	Vertical Sync Output
4	B (Pb)	Analog Blue (Component Pb)
5	G (Y)	Analog Green (Component Y)
6	R (Pr)	Analog Red (Component Pr)

HDMI 2 - Alternative DVI output

PIN	SYMBOL	DESCRIPTION
1	GND	Ground
2	GND	Ground
3	RXC+	TMDS Data C+
4	RXC-	TMDS Data C-
5	RX0+	TMDS Data 0+
6	RX0-	TMDS Data 0-
7	RX1+	TMDS Data 1+
8	RX1-	TMDS Data 1-
9	RX2+	TMDS Data 2+
10	RX2-	TMDS Data 2-
11	GND	Ground
12	GND	Ground
13	MSTR2_SCL	Reserved
14	MSTR2_SDA	Reserved
15	DDC_5V	+5V power supply for DDC
16	HPD	Hot plug detection
17	DDC_SCL	DDC serial clock
18	DDC_SDA	DDC Data
19	VCC1	VCC 5V output
20	VCC2	VCC 5V output

LED2 - Power / Status LED

PIN	SYMBOL	DESCRIPTION
1	Anode_A	Anode of Status LED
2	Cathode_A	Cathode of Status LED
3	Anode_B	Anode of Power LED
4	Cathode_B	Cathode of Power LED

J1 - Audio Out (Line out)

PIN	SYMBOL	DESCRIPTION
1	FRONT_LEFT	Audio left output
2	MIDDLE_RIGHT	Audio right output
3	REAR_GND	Ground

J2 - Composite video Out

PIN	SYMBOL	DESCRIPTION
1	CENTER	Center pin, composite out, 0.7Vp-p
2	GND	Ground

J9 – SD card connector

PIN	SYMBOL	DESCRIPTION
1	CD/DAT3	Card detect / Data Line [Bit 3]
2	CMD	Command / Response
3	VSS1	Supply voltage ground
4	VDD	Supply voltage
5	CLK	Clock
6	VSS2	Supply voltage ground
7	DAT0	Data line [Bit 0]
8	DAT1	Data line [Bit 1]
9	DAT2	Data line [Bit 2]

J10 - RS-232

PIN	SYMBOL	DESCRIPTION
1	NC	No connection
2	5V	+5V (jumper enable/disable)
3	TXD	Tx data
4	RXD	Rx data
5	GND	Ground
6	12V	+12V (jumper enable/disable)

USB1 - USB connector

PIN	SYMBOL	DESCRIPTION
1	UVCC	USB - VCC
2	D-	-VE USB Data
3	D+	+VE USB Data
4	GND	Ground

LAN1 - LAN connector

PIN	SYMBOL	DESCRIPTION
1	TX-	Network Transmit Data
2	TX+	Network Transmit Data

3	RX+	Network Receive Data
4	CMT4	Network Use
5	CMT4	Network Use
6	RX-	Network Receive data
7	CMT3	Network Use
8	CMT3	Network Use
9	GND	Ground
10	GND	Ground

P2 - DVI out

PIN	SYMBOL	DESCRIPTION
1	/RX2	TMDS Data 2-
2	RX2	TMDS Data 2+
3	GND	Digital Ground
4	NC	No connection
5	NC	No connection
6	DDC_CLK	DDC Clock
7	DDC_DAT	DDC Data
8	VS_IN	Analog vertical Sync
9	/RX1	TMDS Data 1-
10	RX1	TMDS data 1+
11	GND	Digital Ground
12	NC	No connection
13	NC	No connection
14	DDC_5V	+5V power supply for DDC
15	GND	Ground (+5, Analog H/V Sync)
16	NC	No connection
17	/RX0	TMDS Data 0-
18	RX0	TMDS Data 0+
19	GND	Digital Ground
20	NC	No connection
21	NC	No connection
22	GND	Digital Ground
23	RXC	TMDS Clock +
24	/RXC	TMDS Clock -
C1	R	Red
C2	G	Green
C3	B	Blue
C4	HS_IN	Analog horizontal sync
C5	GND	Ground
C6	NC	No connection

PP1 - Main power input

PIN	SYMBOL	DESCRIPTION
1	+12_CENTER	+12V DC in center pin
2	GND	Ground

S3 - DIP switch (4-pos) Video out/USB/LAN switch

PW1 – Power On/Off switch connect

PIN	SYMBOL	DESCRIPTION
1	12V_IN	+12V input
2	12V_OUT	+12V output

JA1 – 5V Logic power

PIN	DESCRIPTION
1-2, 3-4	Close (Factory default)

IR1 – Infra-red

PIN	SYMBOL	DESCRIPTION
1	GND	Ground
2	VCC	+5V
3	IR	IR Data

JP1 and JP2 – LAN select

PIN	DESCRIPTION
1-2	Open (wireless adapter) Close (On-board LAN)* *Factory default

JP4 – Watchdog select

PIN	DESCRIPTION
1-2	Open (watchdog disable) Close (watchdog enable)* *Factory default

JP5 – Audio out select

PIN	DESCRIPTION
1-2	Open (J1 line out enable)* Close (CN1 out enable) *Factory default

6 System Setup

6.1 Select switches

Before powering on the M3-320:

- Make sure the corresponding signal cables have been connected from the Composite, or DVI output connector.
- Set the DIP switch (S3) SW-1 to the chosen output connector.
- If select Composite video, set the DIP switch (S3) SW-2 to PAL or NTSC

6.2 OSD Configuration

In OSD configuration mode, you may need external buttons, 8-segmented touch screen or IR remote handset to operate.

Use with external button or 8-segmented touch screen

- To enter OSD configuration mode, holding button 8 and power on. The OSD menu screen will be shown as follow:

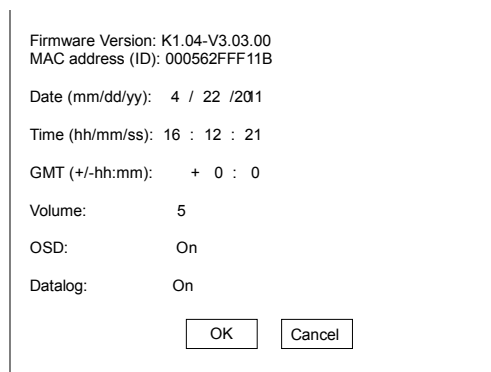

- Press button 8 to select option.
- Press button 7 or button 6 for change value.
- Press button 7 or button 6 to confirm "SAVE AND EXIT".

6.3 Start up

There are two kinds of start up mode (Start track mode and Sleep mode) can be selected when writing playlist on to the SD Card by using DV Studio Software.

6.3.1 Start track mode

If start track mode is selected in playlist, the pre-defined started track will be played first when boot-up. For example, if track #5 is defined as started track, then M3-320 will play track #5 after start up. (The default started track is the first track in playlist)

Step by step:

- Plug in the external power supply
- Insert SD Card containing DV Studio Software exported “.pll / .prj” and other media files. (e.g. .mpg, .avi, .jpg)
- All filename should be in 16.3 format (i.e. xxxxxxxx.xxx) and avoid using any illegal characters like “~”, “_”, “-“, etc
- Switch the power 'on/off' switch to 'on'. (short jumper on PW1)
- The track #5 (started track) will be played first.
- Once the track #5 is finished, the first track in playlist will be followed and played.

6.3.2 Sleep mode

If sleep mode is selected in playlist, a blank screen will be shown at the beginning until the pre-defined button has been pressed. For example, if button# 3 is defined in sleep mode, then M3-320 will play the 1st track until the button #3 is pressed.

Step by step:

- Plug in the external power supply
- Insert SD Card containing DV Studio Software exported “.pll / .prj” and other media files. (e.g. .mpg, .mp3, .jpg)
- All filename should be in 16.3 format (i.e. xxxxxxxx.xxx) and avoid using any illegal characters like “~”, “_”, “-“, etc
- Switch the power 'on/off' switch to 'on'. (short jumper on PW1)
- Press 'button #3'.
- The first track will be played.

Note: special specific track playback activated by assigned button can also be performed in sleep mode - contact local sales office.

6.4 Loop Playback

After Track 1 is set to play, it will play to the end, then Track 2 will start playing from beginning to end, then Track 3 etc. When the M3-320 plays to the end of the last track, it will



automatically jump back to the beginning of Track 1, repeating tracks 1,2 then 3 etc. The M3-320 will play in auto-loop play mode, so long as none of the function buttons are pressed.

(NOTE: Loop playback is the standard playback setting of the M3-320 but the track playback sequence can be changed as required: contact local sales office.)

7 Operating Instructions

7.1 Operating modes

There are two operating modes in M3-320 – “Playlist mode” and “Simple play mode”.

7.1.1 Playlist mode

When operating in playlist mode, both project file (*.prj) and playlist file (*.pl) must be present on the Compact Flash card. These are used to control the sequence for all video tracks.

The project and playlist file are created using **DV Studio** software. Using this software, you can set simple sequences or complex sequences including “jump track” or “next track” actions. DV Studio can also program buttons with different function like “play”, “stop”, “pause”, “mute”, “previous”, “next” and “volume”.

7.1.2 Simple play mode

In simple play mode, the user just copies all video files (.mpg/.avi) or JPEG files (.jpg) onto the Compact Flash card. The M3-320 will play these files in alphabetical sequence.

For JPEG files, the play time can be set by the last digit of the filename. (For example: APPLE5.jpg, where “5” means the track will be displayed for 5 seconds.) *Note: Do not use the same filename on both MPEG and JPEG.*

Note:

- (1) Make sure all capital letters in filename defined in playlist are consistence with the filename on SD card. All filename should be in 16.3 format (i.e. xxxxxxxx.xxx) and avoid using any illegal characters like “~”, “_”, “-“, etc
- (2) All files (including project file and playlist file) must be placed under a folder named “Media” on SD card. For example:

7.2 Operating functions

The following key buttons are default in “Simple Play mode”. (This operation requires button switch-mount or 8-segments touch screen connection.)

PLAY (Button 1)	<ul style="list-style-type: none"> <input type="checkbox"/> Resumes playback of videos from track 1 after STOP has been pressed. <input type="checkbox"/> Resumes playback of the track from the point that it has been set to PAUSE. <input type="checkbox"/> Playback is reset back to the beginning of the specific track which is being played at the time the PLAY button is pressed.
STOP (Button 2)	<ul style="list-style-type: none"> <input type="checkbox"/> When STOP is pressed the video stops playing and a blank screen is displayed.
PAUSE (Button 3)	<ul style="list-style-type: none"> <input type="checkbox"/> When PAUSE is pressed the video image instantly freezes. <input type="checkbox"/> Press Pause again or PLAY to resume normal playback from the position where it was paused.
REPEAT (Button 4)	<ul style="list-style-type: none"> <input type="checkbox"/> When REPEAT is pressed the current track loop back on itself continuously. <input type="checkbox"/> To disable the repeat mode press REPEAT, PLAY, PREVIOUS TRACK or NEXT TRACK . When the track plays to the end it will playback the next track (and etc.) as normal.
NEXT TRACK (Button 5)	<ul style="list-style-type: none"> <input type="checkbox"/> The NEXT TRACK function can be activated only when a track is already playing. When NEXT TRACK is pressed the current video stops playing and jumps directly to the start of the next track.
VOLUME - (Button 6)	<ul style="list-style-type: none"> <input type="checkbox"/> Decreases audio output volume setting.
VOLUME + (Button 7)	<ul style="list-style-type: none"> <input type="checkbox"/> Increases audio output volume setting.
MUTE (Button 8)	<ul style="list-style-type: none"> <input type="checkbox"/> When MUTE is pressed, all the tracks will have no sound. <input type="checkbox"/> Press MUTE again to resume the normal sound in all tracks.

Note : All above buttons can be re-defined by DV Studio * software if operating in playlist mode.

*DV Studio software can be found and downloaded from www.digitalview.com

7.3 USB Update

The M3-320 USB port provides the ability to connect a USB memory stick directly and to read and write data to and from the SD card. To use this USB update function, the DIP switch (SW-4) must set to OFF position. *(Please refer to Application Note* for details)*

*Application Notes can be found and downloaded from www.digitalview.com

- When connect USB memory stick of your M3-320 unit, the power will reset and read the USB content and show the following screen sequences:

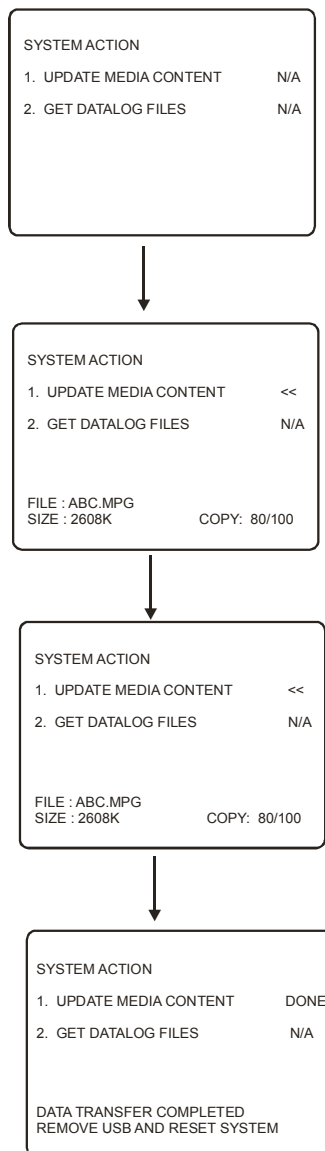

- The M3-320 will reset power again once you remove the USB stick from USB connector.

- A “Media” folder must be created on both USB memory stick and SD card.

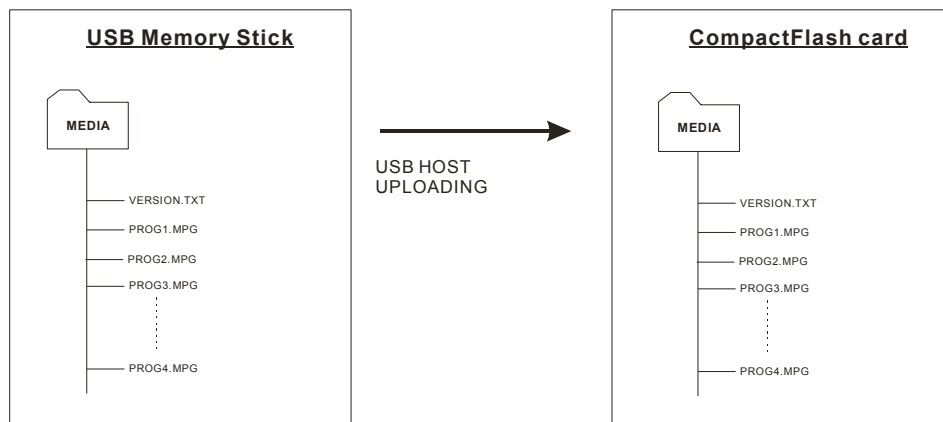

7.4 Formatting SD card

When you bought the new SD card or want to re-used the old SD card. It is suggested to re-format the card with FAT32 again before to export any content on it.

Formatting procedure for Windows:

- Double click the **My Computer** icon on your Windows desktop.
- Right-click the drive name of card reader.
- Click **Format**. The format dialog box appears.
- Click **Start**.

Notes:

- *SD cards should be formatted using FAT32 before first use.*
- *All media files on the SD must be in a folder name “media”.*
- *All media filenames must be in 16.3 format (e.g. xxxxxxxx.xxx) though combinations with 7.3, 6.3 etc are fine. Filenames must be alpha-numeric characters only, not ‘~’, ‘_’, ‘-’, ‘!’, ‘@’, ‘^’, etc.*

7.5 Exporting Project and Playlist

Using DV Studio * software to export your project file (.prj) and playlist file (.pll). Make sure the SD card is formatted with FAT32 and the SD card reader is connected and the driver is well installed. The SD card reader is auto-detected as the 'Removable Disk'

*DV Studio software can be found and downloaded from www.digitalview.com

- Open **DV Studio** software.
- Click **Project** from the menu and select **Open Project**.

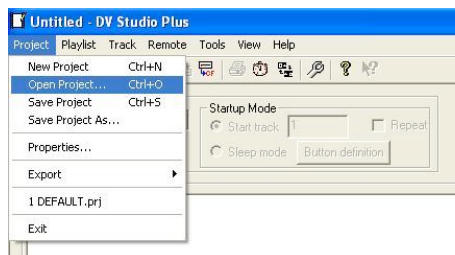

- In the **Project** pull down menu, select **Export** and click **Local Drives**

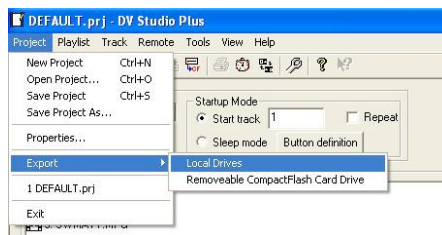

- Click  to select destination drive (i.e. Removable Disk).
- Enter the file path including a **Media** folder to export on SD card (e.g. E:\MEDIA), then click **OK**



- Click **Start** to export.

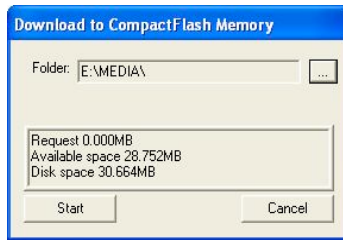

7.6 Network setup

Each M3-320 is shipped with DHCP settings (IP=0.0.0.0). In some network environment, fixed IP could be used and you may need to change the VS-320 with the fixed IP settings. All IP settings are set in a configuration file called "netcfg.ini". To change the IP settings on M3-320 media player, copy the netcfg.ini file with your setting on to MEDIA folder on SD card and restart the player then you will see a boot up message with your IP information changed.

The following is an example of fixed IP settings in netcfg.ini file.

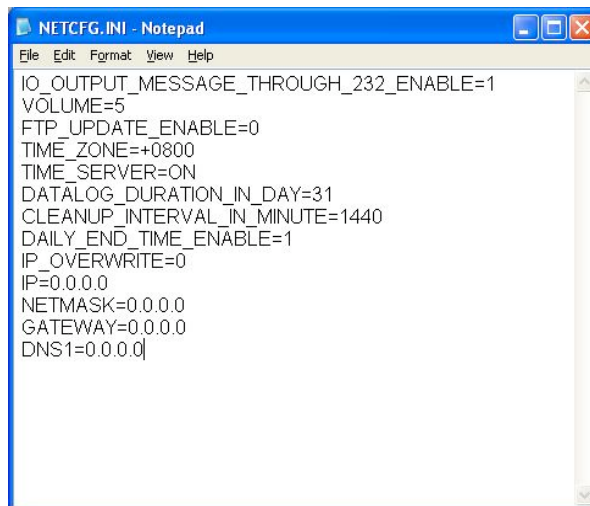

In addition to IP information, the NETCFG.INI file contains some system settings for M3-320 media player. Below is a table to show all user settings in the NETCFG.INI

ITEM	DESCRIPTION
IO_OUTPUT_MESSAGE_THROUGH_232_ENABLE	Enable message output on RS-232 port 0 = Disable message output 1 = Enable message output [Default]
VOLUME	Master volume set, Range (0-10) [Default: 5]
FTP_UPDATE_ENABLE	Enable DV Connect mode 0 = Disable DV Connect mode / Enable DVSync mode 1 = Enable DV Connect mode / Disable DVSync mode [Default: 0]
TIME_ZONE	GMT time zone setting Format: +/- hh [Default: +0]
TIME_SERVER	Set time server OFF = Disable time server polling ON = Enable time server "pool.ntp.org" [Default]
DATALOG_DURATION_IN_DAY	Max. day(s) to keep data log [Default: 31]
CLEANUP_INTERVAL_IN_MINUTE	Interval to clean up data log [Default: 1440]
DAILY_END_TIME_ENABLE	Stop playing End of Day 0 = disable 1 = enable [Default]
IP_OVERWRITE	Change IP settings on player 0 = Keep the old IP settings on player [Default] 1 = Overwrite with new IP settings on player
IP	IP address 0.0.0.0 = DHCP mode [Default: 0.0.0.0]
NETMASK	Subnet mask (Ignore if set to DHCP) [Default: 0.0.0.0]
GATEWAY	Gateway value (Ignore if set to DHCP) [Default: 0.0.0.0]
DNS1	DNS table [Default: 0.0.0.0]

9 Specification

Playable formats	1. MPEG-2 (PS) .mpg @3Mbit/s - Recommended 2. JPEG (.jpg) up to 1280x720 pixels
Storage media	SD card Recommended max capacity: 16GB
Video output resolution	DVI / VGA – 1280x720@60Hz Composite - 720x576(PAL), 720x480(NTSC)
Audio volume	Controlled through OSD with switches attached
Line out	Stereo phone jack (3.5mm)
Playback functions	Play / Stop / Pause / Repeat / Previous track / Next track / Volume / Mute Loop playback / Sequence play / Startup mode / Sleep mode
External I/O ports	RS-232 (57600, N-8-1) USB (content upload) Infra-red (use with DV IR handset, P/N:559000104-3) Remote Ext. (for 8-button & touch)
LAN	RJ-45 LAN connector
LEDs	Power LED (Green) Status LED (Green)
Watchdog	System level auto-reset
Real time clock	Battery-backup RTC
Power requirement	Regulated DC 12V input. 2.5mm center positive.
Power consumption	500mA @ 12V
Environmental	Operating temperature : 0°C to 50°C Relative humidity : 5%-95% relative humidity (Non-condensing)
Dimensions	146.9mm (W) x 91.4mm (D) x 18mm (H)
Weight (net)	135g

WARRANTY

The products are warranted against defects in workmanship and material for a period of three (3) year from the date of purchase provided no modifications are made to it and it is operated under normal conditions and in compliance with the instruction manual.

The warranty does not apply to:

- Product that has been installed incorrectly, this specifically includes but is not limited to cases where electrical short circuit is caused.
- Product that has been altered or repaired except by the manufacturer (or with the manufacturer's consent).
- Product that has subjected to misuse, accidents, abuse, negligence or unusual stress whether physical or electrical.
- Ordinary wear and tear.

Except for the above express warranties, the manufacturer disclaims all warranties on products furnished hereunder, including all implied warranties of merchantability and fitness for a particular application or purpose. The stated express warranties are in lieu of all obligations or liabilities on the part of the manufacturer for damages, including but not limited to special, indirect consequential damages arising out of or in connection with the use of or performance of the products.

CAUTION

Whilst care has been taken to provide as much detail as possible for use of this product it cannot be relied upon as an exhaustive source of information. This product is for use by suitably qualified persons who understand the nature of the work they are doing and are able to take suitable precautions and design and produce a product that is safe and meets regulatory requirements.

SAFETY INSTRUCTION

Do not use this product near water, for example, near a bathtub, wash bowl, kitchen sink, laundry tub, in a wet basement or near a swimming pool.

LIMITATION OF LIABILITY

The manufacturer's liability for damages to customer or others resulting from the use of any product supplied hereunder shall in no event exceed the purchase price of said product.

TRADEMARKS

The following are trademarks of Digital View Ltd:
Digital View
M3-320

Contact Details

USA

18440 Technology Dr.
Building 130, Morgan Hill, CA 95037
USA

Tel: +1-408-782-7773 | **Fax:** +1-408-782-7883

Email: ussales@digitalview.com

--

Europe

6 Marylebone Passage,
London, W1W 8EX
United Kingdom

Tel: +(44)0207 631 2150 | **Fax:** +(44)0207 631 2156

Email : uksales@digitalview.com

--

HongKong

16th floor Millennium City 3
370 Kwun Tong Road, Kwun Tong
HONG KONG

Tel: +852-2861-3615 | **Fax:** +852-2520-2987

Email : hksales@digitalview.com

www.digitalview.com