

Remote Player 400

MANUAL

Version 1.0

Table of Contents

1	Introduction.....	2
1.1	Guide to the Remote Player 400	2
2	Setup.....	3
2.1	Initial setup	3
2.2	Content preparation and update	5
2.3	Additional functions	6
3	Content Update	7
3.1	Preparation	7
3.2	USB upload	8
3.3	UPDATE.INI	10
3.4	Partial update.....	11
3.5	UPDATE.LOG	13
4	FAQ	14
5	Troubleshooting	17
6	Specifications.....	19

Revision History

Amendment Date	Version
December 2008	V1.0

1 Introduction

The Remote Player 400 (RP-400) is a powerful yet easy to use commercial HD (High Definition) digital media player designed for retail point of purchase (POP) product promotions, product demonstration videos, museum information displays, and similar applications that require the solutions to be operated within a network.

Note: Please refer to separate **Network Set-up/Operation Guide** for specific information on how to use the RP-400 via a local LAN or the internet.

1.1 Guide to the Remote Player 400

Diagram 1 – Remote Player 400

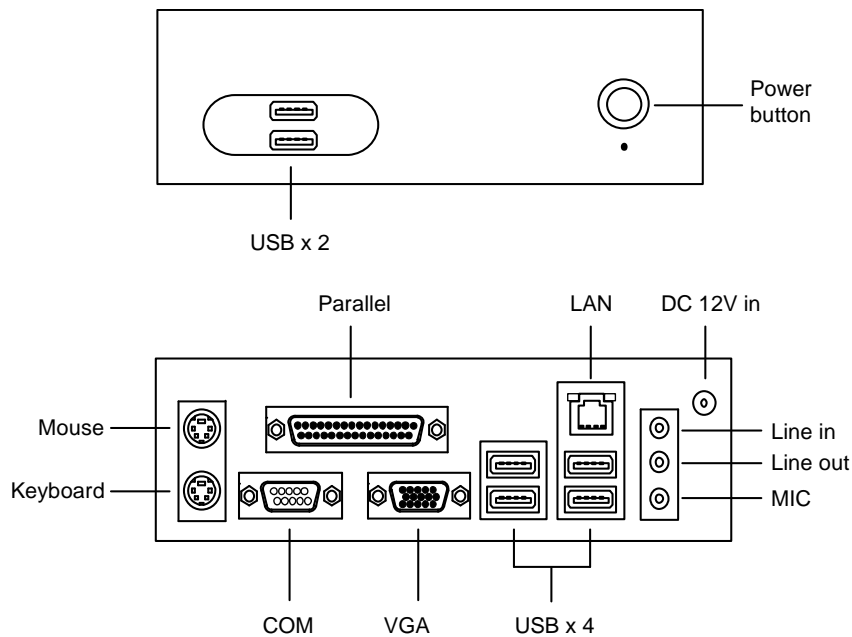

Description	Use
Power button (with power LED)	Power on/off button
USB x 2 (front), USB x 4 (rear)	Content update
Parallel port	Not used
LAN (RJ-45)	Network connection
DC 12V in	DC 12V power input
Line in	Not used
Line out	Audio out
MIC	Not used
VGA	1280x720p output
COM	Reserved for button control
Keyboard	Not used
Mouse	Not used

2 Setup

The Remote Player 400 is designed as an "Auto Play" system which means that when powered "on" it will automatically play media stored on its hard-disk. Media will be played in alphanumeric order based on the filename or in accordance with a playlist if one is present.

There are three steps to consider:

- Initial setup of the Remote Player 400 and a display
- Preparing and updating of content
- Special functions:
 - Playlist
 - Data Logging
 - Scheduling
 - Firmware upgrade

2.1 Initial setup

Steps to follow:

- **VGA Connection:** Connect the Remote Player 400 to a TV type display or monitor using a VGA cable.

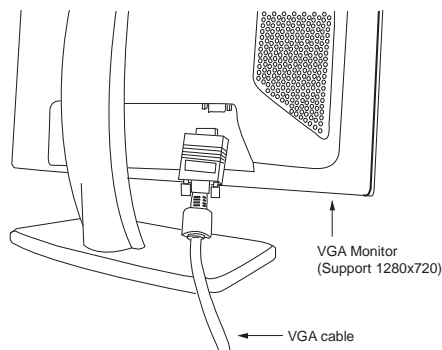

The display must be able to support 1280x720 resolution though it may require setup – see below.

- **RJ-45 Connection:** Connect a RJ-45 LAN cable to Remote Player 400.

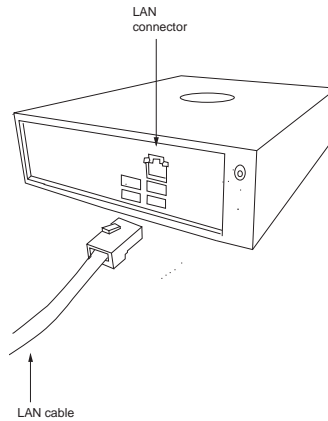

- **Power "on":** Ensure both Remote Player 400 and display are connected to power and switched on. The order is not important but it is recommended to switch the display on first so that you can watch what appears on the screen.

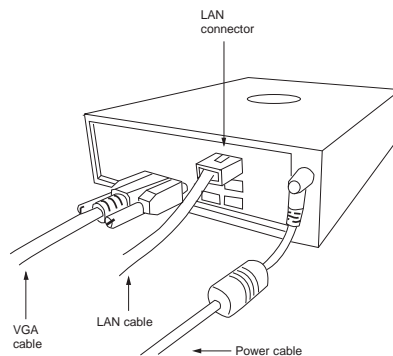

What you should see on the screen:

The startup (boot up) sequence, this will be some text scrolling up the screen. If nothing appears within 30 seconds, please refer to the **Troubleshooting section** in this manual.

When the startup has completed the system should start to play video or still images depending on what has been loaded and the play order.

If there is no picture it is possible that no media is loaded, please refer to section **2.2 Content preparation and update** below. If you believe content is loaded it is worth going through section 2.2 again just to check that all steps were followed. Otherwise please check the Troubleshooting section in this manual or call technical support.

If the picture looks faulty then it is likely that the display requires an initial setup. Typically this will mean using the on screen menu of the display, finding a command such as "Auto Setup" or similar and selecting that.

2.2 Content preparation and update

To update content on the player, plug-in a suitably prepared USB memory stick on any of the USB connectors. The USB stick must contain the content files stored in a "MEDIA" folder. (Refer "**Section 3 – Content Update**" for details)

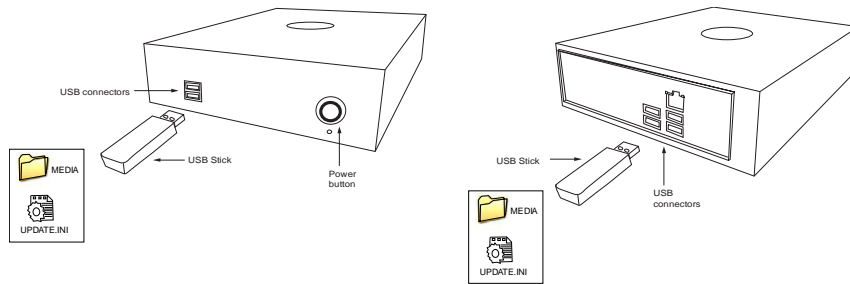

☞ Filename up to 16 characters long are supported with file extension .mpg and .jpg.

☞ Do not use any "Non alpha-numeric" characters like '~', '_', '-', '&', '^', etc.

NOTE: If 'Non alpha-numeric character' or the '16.3' format are not followed, the player will not recognize the playlist.

NOTE: If using DV Studio to generate playlist, the filename must be 8.3 format due to the file system restriction by the DV Studio.

A Playlist is optional, for details on how to prepare, see the Additional Functions section (page 4). Without a playlist, media will play in alpha-numeric order according to the filename.

- **Video:** For standard definition (SD) video, it is recommended to use DVD settings in the preparation and encoding of video. Many popular video editing programs have a DVD setting however it is important that the file produced is .mpg for MPEG-1 & 2 or .avi for DivX (see the Specification in this manual for suitable encoding bit rate).

- SD video: MPEG-2 (.mpg) Encoding bit rate (5Mbit/s)

With Hi-definition video (HD/720p), it is recommended to use MPEG-2 encoding video with max. 12Mbps bit rate:

- HD 720p video: MPEG-2 (.mpg) Encoding bit rate (12Mbit/s)

- **JPEG still images:** A compression setting of "medium" to "good" is recommended. Resolution settings:
 - For output to a widescreen display: 1280x720
 - For output to a standard 4:3 display: 1024x768

- **Display:** There is a very wide selection of displays on the market that are suitable for use with the Remote Player 400. Users are however recommended to consider the following:
 - Video resolution: The Remote Player 400 only supports VGA output. Consequently a display with good scaling will produce optimal results.
 - Aspect ratio: Many displays available are now widescreen type with an aspect ratio of 16:9. However PAL/NTSC is 4:3. Consequently SD video output to widescreen displays may be slightly stretched. In most cases this is not very noticeable but if it is a concern it can be compensated for during the video production and encoding process.
 - Monitor adjustment: VGA output is currently set to 1280x720 resolution which may not be supported by all monitors. Sometimes you have to do auto adjust function through the monitor to fit image on screen. If the display looks reasonable but not perfect, please use the On Screen Display (OSD) menu of the monitor to adjust image position and tuning (sometimes called phase). It may also be necessary to adjust the image size.

2.3 Additional functions

The Remote Player 400 offers a wide selection of options as briefly introduced below. For more information on each of these please refer to detailed application notes that may be added from time to time at www.digitalview.com.

- **Playlist:** By default, videos and still images play in alphanumeric order by filename. Using DV Studio, available for download from www.digitalview.com, files can be played in a specified order.
- **Data Logging:** Create log files containing a cumulative log of events that lists the date, time and track that was played.
- **Scheduling:** Multiple playlists can be loaded and scheduled to play at specified times.
- **Firmware upgrade:** From time to time the operating system of the Remote Player 400 may be upgraded providing bug fixes and new features. For compatible hardware it is possible to install these upgrades through a simple process.
- **Customization:** Digital View provides customization services. Please contact your local office for enquires.

3 Content Update

This section explains the use of USB memory stick for content update. The content such as video, images, playlist file and configuration files (e.g. netcfg.ini, schedule.ini, etc) are updated through a USB memory stick.

3.1 Preparation

USB Memory Stick

- Ensure the USB memory stick is formatted as FAT32 and no “Password control” files are installed on it.
- Create a new folder “MEDIA” on the USB memory stick.
- Create a text file named “UPDATE.INI” * on the root directory. Please refer to the **UPDATE.INI** section for details.

 The USB update does not work without this update.ini file.

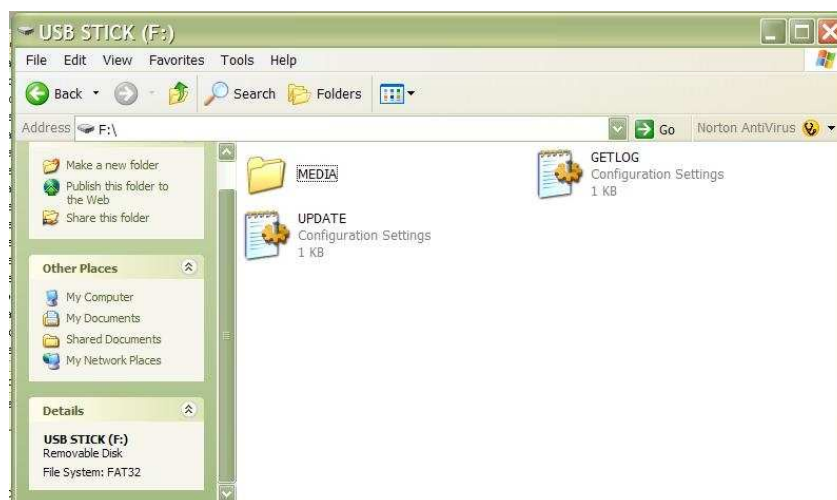

- Copy content (.mpg, .jpg, .ini etc.) into the “MEDIA” folder. These files are now prepared for uploading to the Remote Player 400.

3.2 USB upload

Upload new media content

Step 1: Make sure Remote Player 400 is powered off before inserting the USB memory stick.

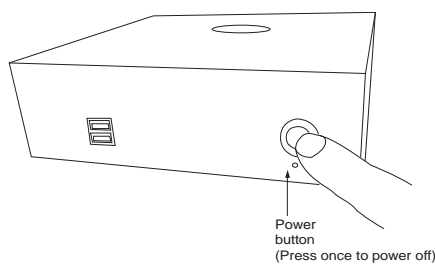

Step 2: Insert USB memory stick with content and "update.ini" saved to Remote Player 400.

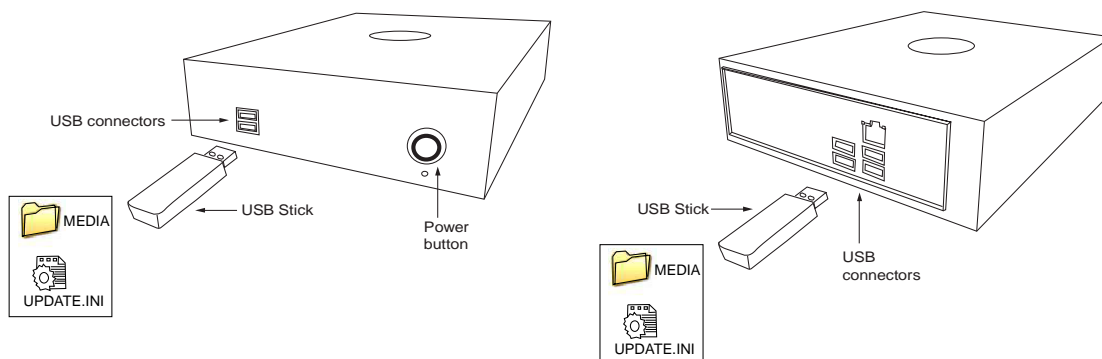

Step 3: Power on Remote Player 400.

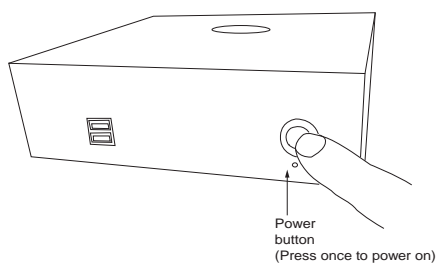

When the media content is being copied from USB memory stick to Remote Player 400. A screen message will be shown as below:

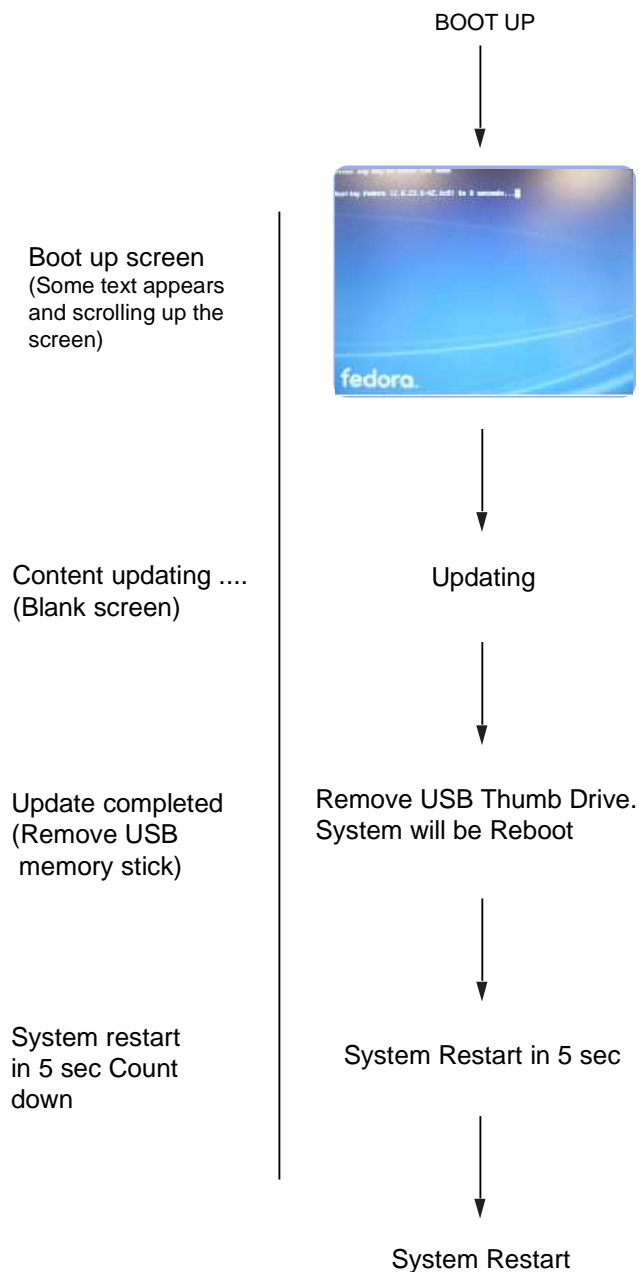

Once the file copy is completed, the following message will be shown:

Remove USB Thumb Drive. System will Reboot

System will restart 5 seconds after the USB thumb drive has been removed.

3.3 UPDATE.INI

This is a text file to control the file transfer mechanism between player and the USB memory stick. This file must contain the description and options as shown in the example file below and placed in the root directory on the USB memory stick. This “Update.ini” file can be created manually or generated by a software tool “USBupdate1.00.exe” (download “USB Host Update/Memory Stick Application...” from :

<http://www.digitalview.com/ViewStream/software.php>

Note: It is ok to use the ViewStream 400 version with the Remote Player 400

Screen of “USBupdate1.00.exe”:



Note: This software tool requires Microsoft .NET Framework to execute. If your computer does not have the Microsoft .NET Framework installed. Please go to the <http://www.microsoft.com> to download and install the latest .NET Framework.

Example of the “update.ini” text file:

```
[update]
USB host file update options:
-----
1. Files present in both Player and USB flash drive
(*) Keep the files in Player unchanged
() Replace the files in Player by those in USB flash drive
-----
2. Files present in Player only
(*) Keep the files in Player unchanged
() Delete the files
-----
3. Files present in USB flash drive only
(*) Copy the files from USB flash drive to Player
() Do nothing
-----
```

 The USB update does not work without this update.ini file.

3.4 Partial update

You can update all or some of the files. A partial update is defined in the “update.ini” file stored on a USB Memory Stick. The following cases explain how the options work.

Case (I) – Overwriting all files

Use this when you want to overwrite the player with new content and new playlist, and remove all those files which are not used in the current playlist. This will save storage space on your HDD. Copy the new content and new playlist on to the USB memory stick, and set the option as below.

```
[update]
USB host file update options:
-----
1. Files present in both Player and USB flash drive
( ) Keep the files in Player unchanged
(*) Replace the files in Player by those in USB flash drive
-----
2. Files present in Player only
( ) Keep the files in Player unchanged
(*) Delete the files
-----
3. Files present in USB flash drive only
(*) Copy the files from USB flash drive to Player
( ) Do nothing
-----
```

Case (II) – Partially file(s) update

To save time, if you just want to update some of the files in a playlist and avoid downloading again any file(s) that already exist on the player. Copy the files you want to update on to the USB memory stick and set the options as below.

```
[update]
USB host file update options:
-----
1. Files present in both Player and USB flash drive
( ) Keep the files in Player unchanged
(*) Replace the files in Player by those in USB flash drive
-----
2. Files present in Player only
(*) Keep the files in Player unchanged
( ) Delete the files
-----
3. Files present in USB flash drive only
(*) Copy the files from USB flash drive to Player
( ) Do nothing
-----
```

Apart from the two cases above, you can define any updating rule by different options combination in the update.ini file.

3.5 UPDATE.LOG

A log file "Update.log" will be created automatically on the USB memory stick once the upload process is done successfully. This log file records the history of the content update as shown in the example as below:

```
[2008-08-14 11:39:54]DELETE:1024x768.jpg  
[2008-08-14 11:39:54]DELETE:1280x720.jpg  
[2008-08-14 11:39:54]DELETE:720M208M.MPG  
[2008-08-14 11:39:54]DELETE:A.pll  
[2008-08-14 11:39:54]DELETE:default.prj  
[2008-08-14 11:39:54]DELETE:dscf0026.jpg  
[2008-08-14 11:39:54]DELETE:msd.avi  
[2008-08-14 11:39:54]DELETE:schedule.ini  
[2008-08-14 11:40:07]COPY:720M220MB.MPG  
[2008-08-14 11:40:08]COPY:J3.JPG  
[2008-08-14 12:09:13]COPY:720H205M.AVI  
[2008-09-09 09:03:41]COPY:DEFAULT.PRJ  
[2008-09-27 12:36:58]COPY:NETCFG.INI
```

4 FAQ

Q: What USB memory stick are suitable?

A: SanDisk USB memory stick is recommended however many other brands are suitable. If the USB stick comes with some security files or bootable files, please remove them before use on the Remote Player 400.

Q: How do I prepare a media file on the USB stick for an USB update ?

A: All media files on the USB memory stick must be in a folder name "Media". Please refer to the detailed "USB update" application notes at <http://www.digitalview.com/viewstream/documentation.php#notes>.

Q: How do I encode or prepare suitable video?

A: Settings equivalent to those used for making a DVD are recommended and many popular video editors have a DVD setting preset. For 720p HD video, use MPEG-2 @12M encoded bitrate.

Q: How do I get video and still images to play in a particular order?

A: It is possible to create a playlist to specify the playback order by using DV Studio which can be downloaded from <http://www.digitalview.com/viewstream/software.php>.

Q: What is DV Studio?

A: An authoring tool from Digital View for the creation of playlists and additional functions with the Remote Player 400 in stand-alone form.

Q: How do I get the most out the advanced features?

A: A good place to start is with the Application Notes on the website as these will explain how the various features work. In addition Digital View's sales support team can provide assistance and ideas.

Q: What customization is possible?

A: Digital View provides both software and hardware customization services – please contact Digital View’s sales support team for assistance.

Q: Why do I notice a ‘Vertical stripe’ pattern on VGA output in some VGA monitors?

A: Since the timing of 1280x720 is not a standard timing in the VESA specification (VGA specification). Therefore most VGA monitors will handle this timing in its own way.

When the vertical strips are found on the screen, that means the VGA monitor connected to the Remote Player 400 did not have the corresponding matched input timing mode. In this case, what we suggest to do is to adjust the phase frequency of the monitor until all the stripes have been removed.

Each VGA monitor should have a Phase frequency adjustment (or called ‘H-size’, ‘H. Freq’, etc) in the OSD menu. Use this function to fine tune the phase until all the stripes are not visible. This adjustment is only needed once in the first time setup, and then the monitor should remember the settings.

Q: What is the best content (JPEG) resolution on VGA output?

A: For JPEG VGA output on the Remote Player 400, it is recommended to use JPEG with 1280x720 resolution.

Q: What is the best content (MPEG) resolution on VGA output?

A: For MPEG VGA output on the Remote Player 400, it is recommended to use 1280x720p MPEG-2 encoding media with 12M encoded bit rate.

Q: How to set local date and time on the player?

A: You have to add a command line in to **netcfg.ini** file. The command line must contain your local GMT time zone. For example:

```
[TIMEZone config]
TIME_ZONE=+8
```

Q: **How to set master volume on the player?**

A: You have to add a command line in to **netcfg.ini** file. The command line must contain volume a value range from 0-32. (Default is 16) For example:

```
VOLUME=20
```

Q: **How to configure dynamic IP (DHCP) on the player?**

A: You have to set the IP address as 0.0.0.0 in to **netcfg.ini** file. The command line must contain IP / Netmask / Gateway and DNS For example:

```
[IP config]  
IP=0.0.0.0  
NETMASK=0.0.0.0  
GATEWAY=0.0.0.0  
DNS1=0.0.0.0  
DNS2=0.0.0.0
```

5 Troubleshooting

<p>Problem:</p> <p>Check & Correction:</p>	<p>Nothing is displayed on the screen:</p> <ul style="list-style-type: none"> • First check that all parts of the system are connected and powered on. • Check that the display is getting a signal from the Remote Player 400. This can be done by ensuring the Remote Player 400 indicator LED is on then powering the Remote Player 400 on & off, the display should flicker. • Ensure the media is compatible, see specifications. • Ensure that files are in a compatible format.
<p>Problem:</p> <p>Check & Correction:</p>	<p>The display has vertical lines in it:</p> <ul style="list-style-type: none"> • This may happen when a monitor is connected using the VGA connector. It can be corrected using the Tuning or Phase function accessed via the OSD (On Screen Display) menu on the monitor.
<p>Problem:</p> <p>Check & Correction:</p>	<p>The display is shifted to the side:</p> <ul style="list-style-type: none"> • This may happen when a monitor is connected using the VGA connector. It can be corrected using the position adjustment controls function accessed via the OSD (On Screen Display) menu on the monitor.
<p>Problem:</p> <p>Check & Correction:</p>	<p>The display cannot fit the whole screen:</p> <ul style="list-style-type: none"> • VGA output is currently set to 1280x720 resolution which may not be supported by all monitors. Sometimes you have to do auto adjust function through the monitor to fit image on screen.
<p>Problem:</p> <p>Check & Correction:</p>	<p>Video is jerky:</p> <ul style="list-style-type: none"> • It is likely that the video is encoded at a data rate too high for the player. • The 720p HD video was not encoded by MPEG-2

<p>Problem: Video is very blocky:</p> <p>Check & Correction:</p>	<ul style="list-style-type: none"> • The 720p HD video was not encoded in MPEG-2 • The SD video encoding settings are for a lower resolution. DVD settings are recommended. • Original content was low resolution
<p>Problem: Text is not readable:</p> <p>Check & Correction:</p>	<ul style="list-style-type: none"> • It is likely that the text is too small however it is worth checking the encoding settings. DVD settings are recommended.
<p>Problem: Audio playback is intermittent:</p> <p>Check & Correction:</p>	<ul style="list-style-type: none"> • It is likely that the video is encoded at a data rate too high for the player.
<p>Problem: Video in the playlist does not play in accordance with the play sequence.</p> <p>Check & Correction:</p>	<ul style="list-style-type: none"> • Make sure both project (.prj) and playlist (.pll) have been uploaded on the player. Check if these two files were present in the USB memory stick before content update.

6 Specifications

Playable formats	<p>SD content: MPEG-1 (.mpg) Encoding bit rate: 1.15Mbit/s MPEG-2 (.mpg) Encoding bit rate: 5Mbit/s</p> <p>HD content (720p): MPEG-2 (.mpg) Encoding bit rate: 12Mbit/s</p> <p>JPEG content: JPEG (.jpg) up to 1280x720 pixels</p>
Storage media	SATA 120G Hard drive
Video output resolution	VGA – 1280x720
Line out	Stereo
Playback functions	Loop playback / Sequence play /Schedule playback
External I/O ports	USB (content upload)
LEDs	Power LED
Real time clock	Battery-backup RTC
Power requirement	Regulated DC 12V input. 2.5mm center positive.
Power consumption	2.2A @ 12V
Environmental	<p>Operating temperature : 0°C to 50°C : 32°F to 122°F</p> <p>Relative humidity : 5%-95% relative humidity (Non-condensing)</p>
Dimensions	180mm (W) x 235mm (D) x 58mm (H) 7.09 in (W) x 9.25in (D) x 2.28 in (H)
Weight (net)	1.2kg (2.65 lbs)

WARRANTY

The products are warranted against defects in workmanship and material for a period of one (1) year from the date of purchase provided no modifications are made to it and it is operated under normal conditions and in compliance with the instruction manual.

The warranty does not apply to:

- Product that has been installed incorrectly, this specifically includes but is not limited to cases where electrical short circuit is caused.
- Product that has been altered or repaired except by the manufacturer (or with the manufacturer's consent).
- Product that has subjected to misuse, accidents, abuse, negligence or unusual stress whether physical or electrical.
- Ordinary wear and tear.

Except for the above express warranties, the manufacturer disclaims all warranties on products furnished hereunder, including all implied warranties of merchantability and fitness for a particular application or purpose. The stated express warranties are in lieu of all obligations or liabilities on the part of the manufacturer for damages, including but not limited to special, indirect consequential damages arising out of or in connection with the use of or performance of the products.

CAUTION

Whilst care has been taken to provide as much detail as possible for use of this product it cannot be relied upon as an exhaustive source of information. This product is for use by suitably qualified persons who understand the nature of the work they are doing and are able to take suitable precautions and design and produce a product that is safe and meets regulatory requirements.

SAFETY INSTRUCTION

Do not use this product near water, for example, near a bathtub, wash bowl, kitchen sink, laundry tub, in a wet basement or near a swimming pool.

LIMITATION OF LIABILITY

The manufacturer's liability for damages to customer or others resulting from the use of any product supplied hereunder shall in no event exceed the purchase price of said product.

TRADEMARKS

The following are trademarks of Digital View Ltd:
Digital View REMOTE PLAYER 400

CONTACT DETAILS

ASIA: Digital View Ltd
16th floor Millennium City 3
370 Kwun Tong Road
Kwun Tong
Hong Kong

Tel: (852) 2861 3615

Sales: hksales@digitalview.com

Fax: (852) 2520 2987

EUROPE: Digital View Ltd
6 Marylebone Passage
London
W1W 8EX
UK

Tel: (44) (0)20 7631 2150

Sales: uksales@digitalview.com

Fax: (44) (0)20 7631 2156

USA: Digital View Inc.
18440 Technology Drive
Building 130
Morgan Hill, CA 95037

Tel: (1) 408-782 7773

Sales: ussales@digitalview.com

Fax: (1) 408-782 7883

Specifications subject to change without notice

Document no.: 9160040-10 Remote Player 400 Manual (December 2008) © Digital View Ltd 2008