



Analog Video To Digital Adaptor Board

Model: AVD-2000

Part number : 41602341X-3 or up

INSTRUCTIONS

CONTENTS

Page:	2. Introduction
	3. Connectors, Pinouts & Jumpers
	6. LED status and Source switching
	7. AVD-2000 connects with SVX-2560 & SVH-1920v2 as an example
	8. Board dimensions
	9. Appendix I – Mode Support Table
	10. Appendix II – RS-232 control protocols
	11. Warranty, Caution & Limitation of Liability, Trademarks
	12. Contact details
	13. Revision history

It is essential that these instructions are read and understood before connecting or powering up this controller.

Introduction

The Analog video to Digital adaptor board AVD-2000 designs to select one of analog video input sources (Composite and S-Video) and convert to digital video output (HDMI). The video input sources can be selected by DigitalView LCD controller (e.g SVX-2560) via I²C interface. It provides 4 x Composite video and 4 x S-Video input and can be configured to support 8 x Composite video input by firmware modification.

Ordering information :

Controller	Part number	Ordering part number
AVD-2000	P/N 41602341X-3	P/N 4160234XX-3

Video Inputs Signal Format :

- NTSC (M, J, 4.43)
- PAL (M, BDGHI, Nc, 60)

Video Output Signal Format: HDMI

CONNECTORS, PINOUTS & JUMPERS

The various connectors are:

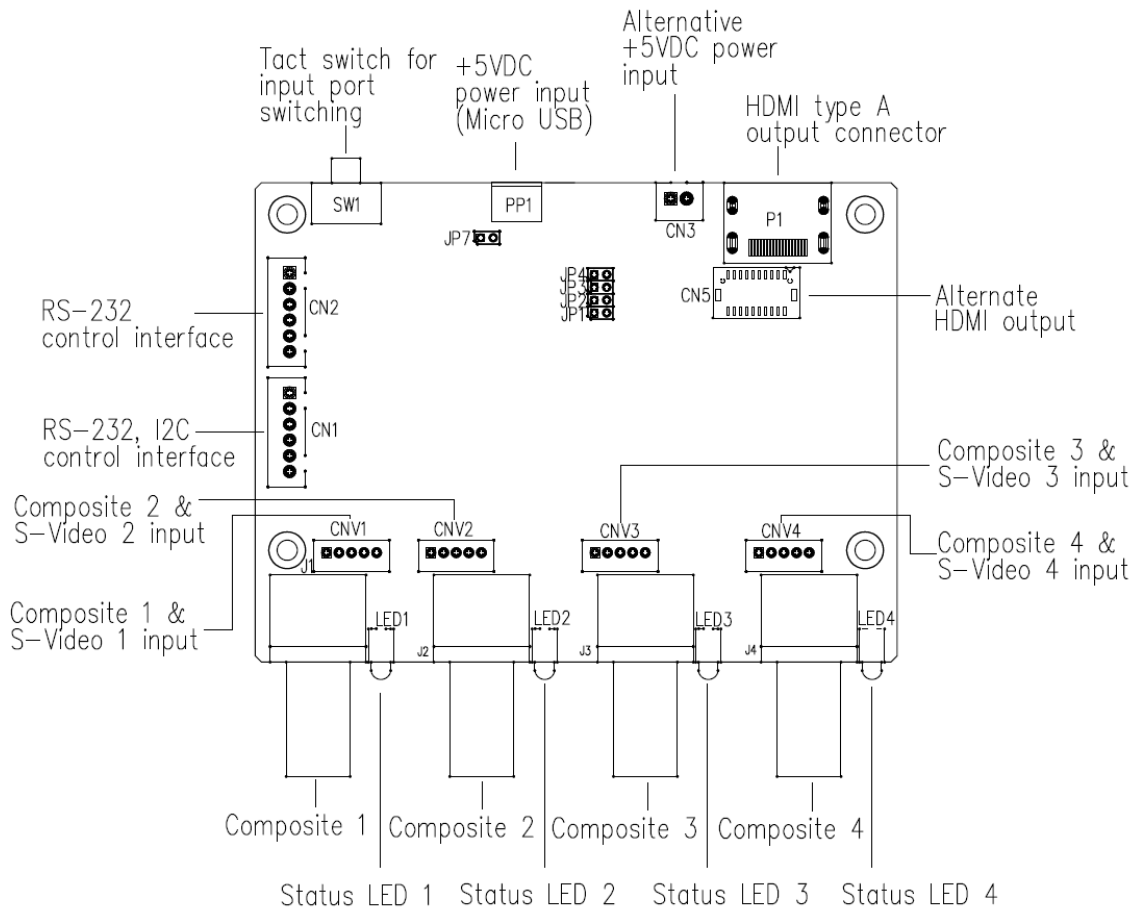

Summary: Connectors

Ref	Purpose	Description
CN1	RS-232 & I ² C control	JST 6-way, B6B-XH-A compatible (Matching type : XHP-6) For ALT/DT-1920 type controller connection uses matching I2C cable : P/N 426091600-3 For SVX-2560/SP-1920 type controller connection uses matching I2C cable : P/N 426091100-3
CN2	Alternate RS-232 control	JST 6-way, B6B-XH-A compatible (Matching type : XHP-6)
CN3	Alternate +5VDC power input (2 ways connector)	JST 2-way, B2B-XH-A compatible (Matching type : XHP-2) (Matching power cable P/N 426023200-3)
CN5	HDMI on board for internal connector	JST BM20B-SRDS (Matching type : SHDR-20V-S-B)
CNV1	Alternate video in (Composite 1 & S-Video 1)	JST 5-way, B5B-PH-K compatible (Matching type : PHR-5) (Matching video cable P/N 426000500-3)
CNV2	Alternate video in (Composite 2 & S-Video 2)	JST 5-way, B5B-PH-K compatible (Matching type : PHR-5) (Matching video cable P/N 426000500-3)
CNV3	Alternate video in (Composite 3 & S-Video 3)	JST 5-way, B5B-PH-K compatible (Matching type : PHR-5) (Matching video cable P/N 426000500-3)
CNV4	Alternate video in (Composite 3 & S-Video 4)	JST 5-way, B5B-PH-K compatible (Matching type : PHR-5) (Matching video cable P/N 426000500-3)
P1	HDMI output	HDMI type A connector
J1	Composite 1 input	BNC connector
J2	Composite 2 input	BNC connector
J3	Composite 3 input	BNC connector
J4	Composite 4 input	BNC connector
PP1	+5VDC power input	Micro USB
SW1	For input port switching	Tact switch

Summary: Jumpers setting

Ref	Purpose	Note
JP1-4	Reserved	Reserved
JP7	Internal programming use	Open = Normal operation (Default) Short = Firmware upgrade use

CN1 – Power & RS-232 control : JST B6B-XH-A compatible (Mating type : XHP-6 or compatible)

PIN	SYMBOL	DESCRIPTION
1	NC	Reserved
2	NC	Reserved
3	VCC	+5V
4	TXD	RS-232 Tx data
5	GND	Ground
6	RXD	RS-232 Rx data

CN2 – Power, RS-232 & I²C control : JST B6B-XH-A compatible (Mating type : XHP-6 or compatible)

PIN	SYMBOL	DESCRIPTION
1	SCLK	I2C slave clock in
2	SDATA	I2C slave data in
3	VCC	+5V
4	TXD	RS-232 Tx data
5	GND	Ground
6	RXD	RS-232 Rx data

CN3 – Power supply socket : JST B2B-XH-A compatible (Mating type : XHP-2 or compatible)

PIN	SYMBOL	DESCRIPTION
1	VCC	Power supply +5V
2	GND	Ground

CN5 – Power, RS-232 & I²C control : JST BM20B-SRDS compatible (Matching type : SHDR-20V-S-B)

PIN	SYMBOL	DESCRIPTION
1	GND	Ground
2	GND	Ground
3	RXC+	TMDS Data C+
4	RXC-	TMDS Data C-
5	RX0+	TMDS Data 0+
6	RX0-	TMDS Data 0-
7	RX1+	TMDS Data 1+
8	RX1-	TMDS Data 1-
9	RX2+	TMDS Data 2+
10	RX2-	TMDS Data 2-
11	GND	Ground
12	GND	Ground
13	MSTR2_SCL	Reserved
14	MSTR2_SDA	Reserved
15	DDC_5V	+5V power supply for DDC (optional)
16	HPD	Hot plug detection
17	DDC_SCL	DDC serial clock
18	DDC_SDA	DDC Data
19	VCC1	VCC 5V output
20	VCC2	VCC 5V output

CNV1 – Alternate video in (Composite 1 & S-Video 1), JST 5 ways, B5B-PH-K compatible (Mating type : PHR-5)

PIN	SYMBOL	DESCRIPTION
1	CHRO1	S-Video 1 chroma in
2	LUMA1	S-Video 1 luma in
3	GND	Ground
4	GND	Ground
5	CVBS1	Composite video 1 in

CNV2 – Alternate video in (Composite 2 & S-Video 2), JST 5 ways, B5B-PH-K compatible (Mating type : PHR-5)

PIN	SYMBOL	DESCRIPTION
1	CHRO2	S-Video 2 chroma in
2	LUMA2	S-Video 2 luma in
3	GND	Ground
4	GND	Ground
5	CVBS2	Composite video 2 in

CNV3 – Alternate video in (Composite 3 & S-Video 3), JST 5 ways, B5B-PH-K compatible (Mating type : PHR-5)

PIN	SYMBOL	DESCRIPTION
1	CHRO3	S-Video 3 chroma in
2	LUMA3	S-Video 3 luma in
3	GND	Ground
4	GND	Ground
5	CVBS3	Composite video 3 in

CNV4 – Alternate video in (Composite 4 & S-Video 4), JST 5 ways, B5B-PH-K compatible (Mating type : PHR-5)

PIN	SYMBOL	DESCRIPTION
1	CHRO4	S-Video 4 chroma in
2	LUMA4	S-Video 4 luma in
3	GND	Ground
4	GND	Ground
5	CVBS4	Composite video 4 in

LED Status and Source switching

On board LED is located beside each video input connector. It turns on when the source is selected. If no video signal is present in the selected source, the LED blinks.

Status LED (LED1-4) :

State	LED status
Input source detected	ON
Input source selected, but no signal detected	Blinks

Video inputs can be selected by:

- On board tact switch to toggle from one input to another one sequentially.
- RS-232 commands

The last selected video input source will be memorized after power cycle.

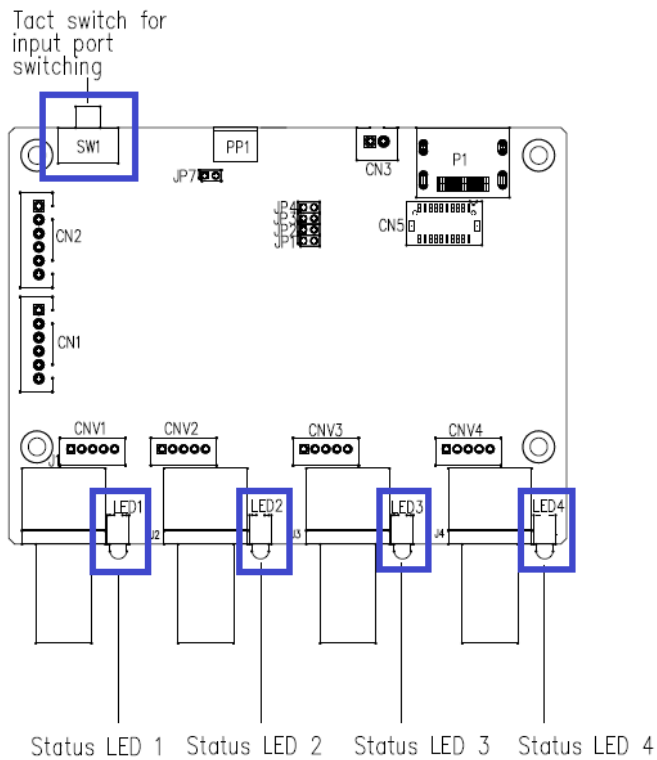

AVD-2000 connects with SVX-2560 & ALT-1920 as an example

AVD-2000 with SVX-2560 connection :

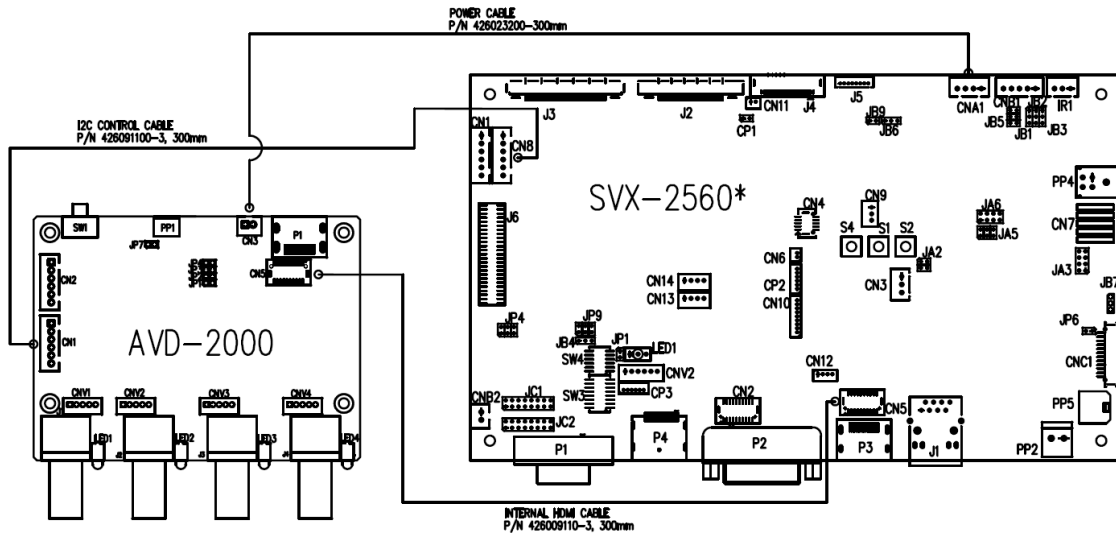

AVD-2000 with ALT-1920 connection :

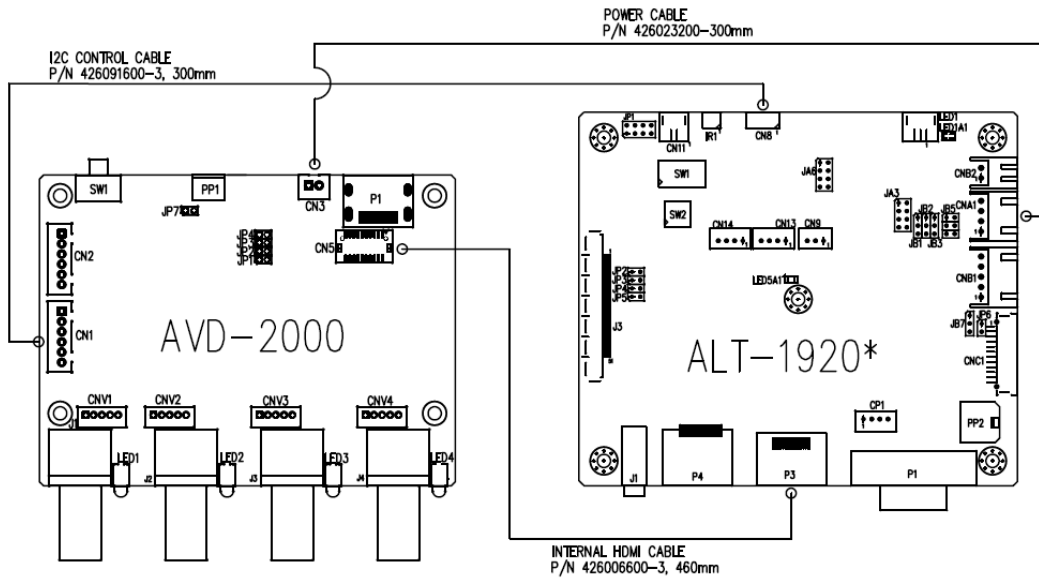

Remark :

* Custom firmware version required.

BOARD DIMENSIONS

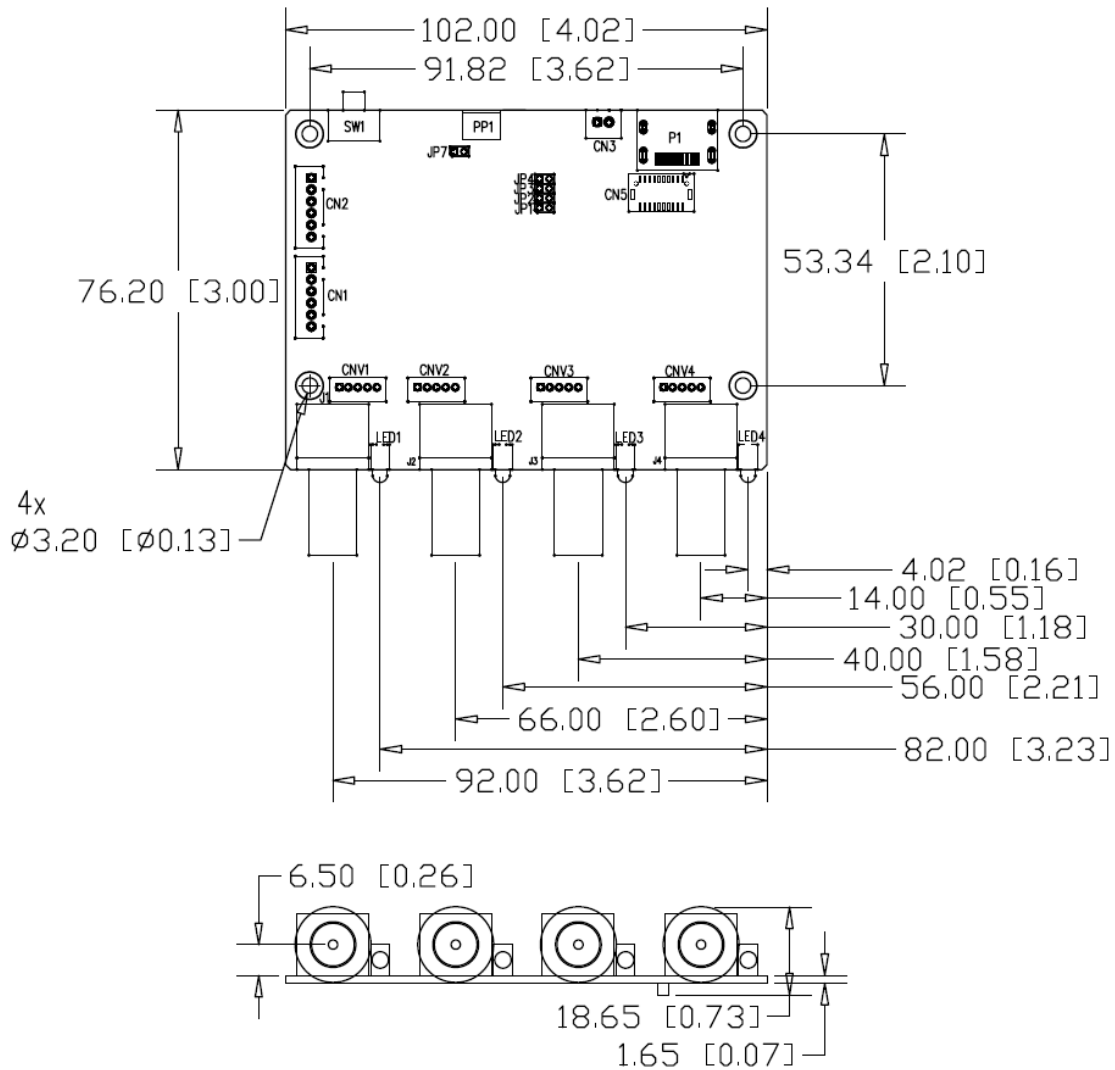

The maximum thickness of the controller is 18.7mm (measured from bottom of PCB to top of components, including any underside components & leads). We recommend clearances of:

- 5mm from bottom of PCB - if mounting on a metal plate we also recommend a layer of suitable insulation material is added to the mounting plate surface.
- 10mm above the components
- 3~5mm around the edges

Any of the holes shown above can be used for mounting the PCB, they are 3.2mm in diameter.

CAUTION: Ensure adequate insulation is provided for all areas of the PCB with special attention to high voltage parts such as the backlight driver.

Appendix I – Mode Support Table

Composite & S-Video port :

Video Inputs Signal Format
NTSC-M
NTSC-J
NTSC 4.43
PAL BDGHI
PAL M
PAL Nc
PAL 60

Appendix II – RS-232 control protocols

RS-232 Serial control (Baud rate 9600, 8 bits, 1 stop bit and no parity)

Physical connection :

Controller side
 Connector interface : CN8
 Mating connector : Molex 51021-0600

Computer side
 Connector interface : Serial port
 Mating connector : DB9 Female



PIN#	Description
4	RS-232 Tx Data
5	Ground
6	RS-232 Rx Data

PIN#	Description
2	RS-232 Rx Data
3	RS-232 Tx Data
5	Ground

Function	Command	Description	Acknowledge (if enabled)
Input main select	0x98, nn "+" "-" "r" "R" "?"	Select input main = VIDEO or next available Reset Query	Main selected. "0x42,0x31" Composite 1 "0x42,0x32" Composite 2 "0x42,0x33" Composite 3 "0x42,0x34" Composite 4 "0x43,0x31" S-Video 1 "0x43,0x32" S-Video 2 "0x43,0x33" S-Video 3 "0x43,0x34" S-Video 4

WARRANTY

The products are warranted against defects in workmanship and material for a period of three (3) year from the date of purchase provided no modifications are made to it and it is operated under normal conditions and in compliance with the instruction manual.

The warranty does not apply to:

- Product that has been installed incorrectly, this specifically includes but is not limited to cases where electrical short circuit is caused.
- Product that has been altered or repaired except by the manufacturer (or with the manufacturer's consent).
- Product that has subjected to misuse, accidents, abuse, negligence or unusual stress whether physical or electrical.
- Ordinary wear and tear.

Except for the above express warranties, the manufacturer disclaims all warranties on products furnished hereunder, including all implied warranties of merchantability and fitness for a particular application or purpose. The stated express warranties are in lieu of all obligations or liabilities on the part of the manufacturer for damages, including but not limited to special, indirect consequential damages arising out of or in connection with the use of or performance of the products.

CAUTION

Whilst care has been taken to provide as much detail as possible for use of this product it cannot be relied upon as an exhaustive source of information. This product is for use by suitably qualified persons who understand the nature of the work they are doing and are able to take suitable precautions and design and produce a product that is safe and meets regulatory requirements.

LIMITATION OF LIABILITY

The manufacturer's liability for damages to customer or others resulting from the use of any product supplied hereunder shall in no event exceed the purchase price of said product.

TRADEMARKS

The following are trademarks of Digital View Ltd:

- Digital View
- AVD-2000

CONTACT DETAILS

Digital View has offices in USA, Europe and Asia also an internet site:

USA

Digital View Inc.
18440 Technology Drive
Building 130
Morgan Hill,
California, 95037
USA

Tel: (1) 408-782 7773 **Fax:** (1) 408-782 7883

Sales: ussales@digitalview.com

EUROPE

Digital View Ltd.
6 Marylebone Passage,
London, W1W 8EX
UK

Tel: +44-(0)20-7631-2150 **Fax:** +44-(0)20-7631-2156

Sales: uksales@digitalview.com

ASIA

Digital View Ltd
Unit 705-708, 7/F Texwood Plaza
6 How Ming Street
Kwun Tong
Hong Kong

Tel: (852) 2861 3615 **Fax:** (852) 2520 2987

Sales: hksales@digitalview.com

WEBSITE

www.digitalview.com

Revision History

Date	Rev No.	Page	Summary
26 Aug 2020	1.00	All	First Issue version.